

Automatic filling units



series 553



cert. n° 0003
ISO 9001

01025/05 GB

Replaces 01025/02 GB



Function

The automatic filling unit is a device consisting of a pressure reducing valve with compensating seat, an inlet strainer, a shut-off valve and a check valve.

It is installed in the water supply pipework in sealed heating systems and its main function is to maintain the system pressure stable at a set value, automatically topping up with water, as required.

After installation, during the filling or topping-up phase, feed will stop when the set pressure is reached.

Product range

Code 553040 Automatic filling units with pressure gauge connection _____ Size 1/2"
Code 553140 Automatic filling units with pressure gauge _____ Size 1/2"

Technical specification

Materials: - body: brass EN 12165 CW617N
- cover: brass EN 12165 CW617N
- seals: NBR

Max. inlet pressure: 16 bar
Pressure setting range: 0,3 – 4 bar
Factory setting: 1,5 bar
Max. working temperature: 70°C
Pressure gauge scale: 0 – 4 bar

Connections: - inlet: 1/2" M with union tailpiece
- outlet: 1/2" F
- pressure gauge connection: 1/4" F

Dimensions

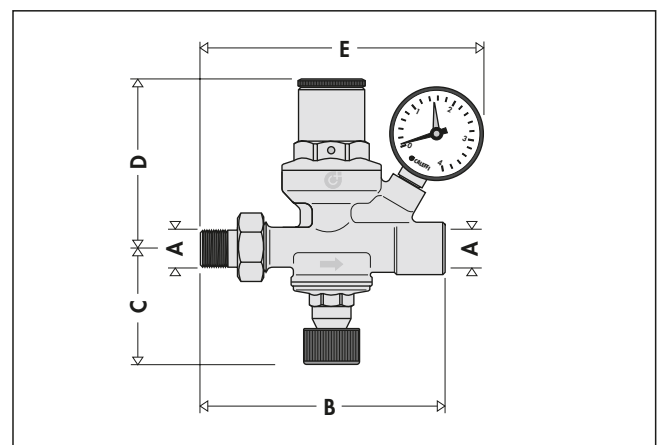

Code	A	B	C	D	E	Weight (kg)
553040	1/2"	122	61	87	-	0,85
553140	1/2"	122	61	87	149	0,95

Construction details

Components

The valve body is made of hot forged brass. The re-inforced rubber control diaphragm is formed in a shape permitting deformation to take place without creating stresses. The only sealing element of the compensating piston is in the upper part of the device, ensuring that impurities cannot be deposited.

Manual / automatic opening

In the lower part of the unit, a manual shut-off valve is provided, which can close off the supply to the system. The automatic condition of operation is restored when the valve is re-opened. The pressure level in the system will gradually return to the set calibration value.

Installation

1. Automatic filling unit code 553040/140 can be installed in either horizontal or vertical position. It is, however, vital that the unit is not installed upside down.

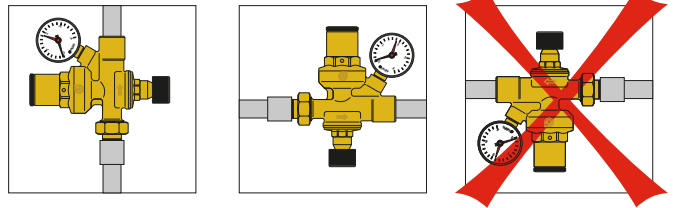

The unit is adjusted by means of the regulator located inside the top cover: rotating it in a clockwise or anticlockwise direction increases or decreases the pressure at which the unit operates.

2. When the system is being commissioned, the unit is normally calibrated at a pressure no lower than the hydrostatic pressure plus 0,3 bar. The internal mechanism will automatically regulate the pressure by closing down the supply on reaching the set value.
3. The system fills slowly, as the amount of water entering is in direct proportion to the amount of air vented.
4. When the system is filled, the shut-off valve can be closed. In order to restore the automatic top-up condition, merely re-open the valve. The pressure in the system will gradually return to the set pressure.

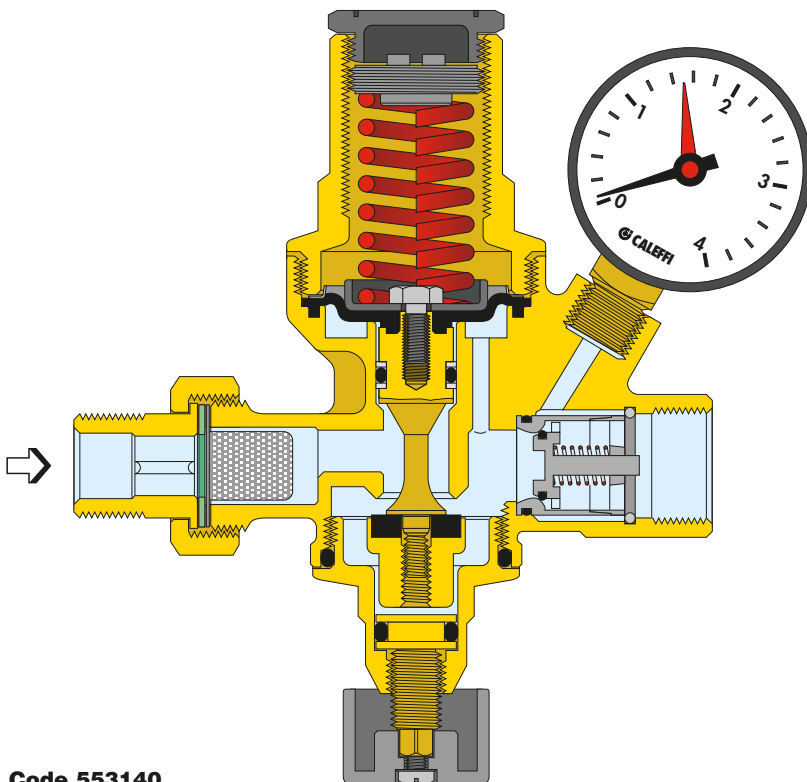

Code 553140

SPECIFICATION SUMMARIES

Series 553

Automatic filling unit. 1/2" M with union tailpiece x 1/2" F threaded connection. Brass body and cover. Diaphragm and seals in NBR. Maximum working temperature 70°C. Maximum inlet pressure 16 bar. Pressure setting range 0,3 – 4 bar. Complete with pressure gauge, scale 0 – 4 bar (or pressure gauge connection), shut-off, strainer and check valve.

We reserve the right to change our products and their relevant technical data, contained in this publication, at any time and without prior notice.

