

DETACH *PRO*

2 Port Motorised Valve Actuator

M1P Actuator



Important: Keep this document

The M1P range of actuators c/w auxiliary switch are specifically designed for use in domestic applications only.

They are not designed for use in commercial or industrial applications such as schools, nursing homes or hotels where large commercial pump sets are fitted.

Warranty will be void if a valve is fitted in any application other than domestic.

Please note we have a full range of commercial and industrial valves to suit every application.

CAUTION! Installation and connection should only be carried out by a qualified person and in accordance with wiring regulations.

- Do not open the products. There are no serviceable or adjustable parts inside. The system must be fused to no more than 3 Amps.
- Isolate mains supply before installation commences.
- Isolate mains supply before attaching cable to actuator.
- Isolate mains supply before detaching cable from actuator.
- If this equipment is installed or used in a way not specified by the manufacturer, its safety may be impaired.

TECHNICAL SPECIFICATION

ACTUATOR	MANUFACTURER	MODEL	SIZE & TYPE
M1P replacement for	Myson	MPE222	22mm Compression
	Myson	MPE 2 3/4	22mm Compression
	Myson	MCZV2 3/4	3/4" Compression
	Myson	MCZV21	1" Compression

ACTUATOR

Motor supply voltage	230V	Impedance protected motor	
Rated impulse voltage	2500V	Auxiliary switch rating	11(3)A
Power consumption	5W	Protection rating	IP20
Max. ambient temperature	50°C		

LEAD SUPPLIED	1.2 metre cable. Earth Connection required.
ACTUATOR OPERATION	230V Power to open - Spring return to close.
	This is not a fail safe, a no fail or a safety product.
	This control is designated Type 1. AA. C in accordance with EN60730.
	Type of action is multi position. Type of movement is rotary.
MANUAL OVERRIDE	Valve may be manually opened for filling or draining the system.
	In normal operation, the lever must be in the Auto position
	If the mains power is disconnected, the valve will automatically spring return to the closed position.

INSTALLATION & OPERATING INSTRUCTIONS

1. Valve positioning

Install the valve so the actuator head is not below the horizontal level of the pipework. The open vent and cold feed must not be isolated. The flow through the valve can be from either direction.

2. Fitting the valve body to the pipework

Compression connection

Fit the valve body using the nuts and olives provided. When tightening the compression nuts ensure that only the valve body is used for grip. Take care not to overtighten. The actuator should not be mounted when fitting the valve.

3. Fitting of actuator to the valve body

- 1) Align the 7mm spindle on the valve body to the identically sized slot on the actuator.
- 2) Rotate the actuator until the fixing lug on the actuator lines up with the lug hole on the mounting plate.
- 3) Insert the two fixing screws (provided) through the actuator and tighten onto the mounting plate.

Once the actuator is fitted, place the manual override lever in the raised manual position. It is now possible to flush and drain the system to remove any foreign matter. The system can now be filled and corrosion inhibitor may be added if required.

4. Wiring Connections

4.1 The 1.2 metre cable can be connected as follows:

WIRE COLOUR	DESCRIPTION
Brown	230V live (normally connected via room or cylinder stat)
Blue	Neutral supply
Grey	Auxiliary switch N/O (normally connected to Boiler and Pump)
Orange	Auxiliary switch COM (normally connected to 230V)
Yellow / Green	Earth connection

CAUTION!

- Ensure that no more than a 3A fuse is used to supply all controls.
- It is not permissible to use any voltage other than 230V on the auxiliary switch.
- Electrical installation must conform with current I.E.E. regulations.

4.2 Diagram:

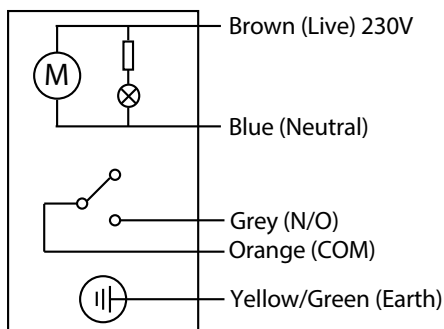

The auxiliary switch can be used as an interlock facility, thereby ensuring any auxiliary equipment is switched OFF when the valve is in the closed position. When the valve is in the fully open position the auxiliary equipment will be switched ON.*

5. Commissioning

Once the system has been filled and vented, carry out the following to ensure correct operation of the valve.

- Ensure the manual override lever is in the Auto position.
- Switch on the relevant channel on the programmer.
- Set the thermostat to maximum.
- The valve should move to the fully open position.
- The auxiliary switch should close and thereby switch ON any auxiliary equipment.*

Once satisfied with valve operation. Reset the programmer and thermostat to normal operating conditions.

* Examples of auxiliary equipment include boilers and pumps

WARNING!

- Under no circumstances should the actuator be insulated or covered by any other material.
- Lack of ventilation will cause the actuator to heat up beyond the maximum permissible ambient temperature of 50°C.

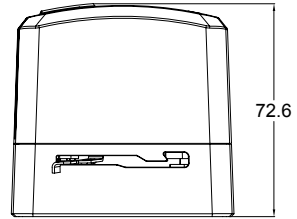
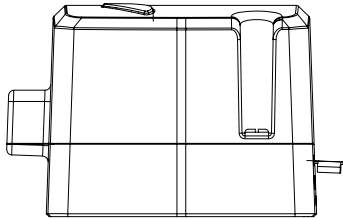
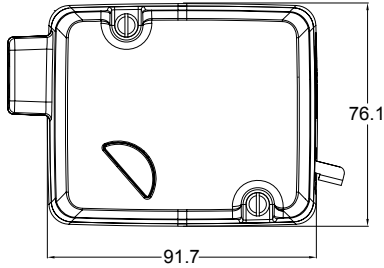

WARNING!

- Under no circumstances should the actuator be insulated or covered by any other material.
- Lack of ventilation will cause the actuator to heat up beyond the maximum permissible ambient temperature of 50°C.

The crossed out wheeie bin symbol on this product indicates that this product must not be disposed of in your general waste. It can be taken to your Local Authority Civic Amenity site for free or returned to your retailer for free when you are buying a replacement. Inappropriate waste handling could lead to negative effects on the environment and human health. With your cooperation you contribute to the correct disposal, reuse, recycling and recovery of the components of this product and the protection of the environment.



EPH Controls IE

T 021 471 8440
technical@ephcontrols.com
www.ephcontrols.com

EPH Controls UK

T 01933 322 072
technical@ephcontrols.co.uk
www.ephcontrols.co.uk